

Sash Fasteners

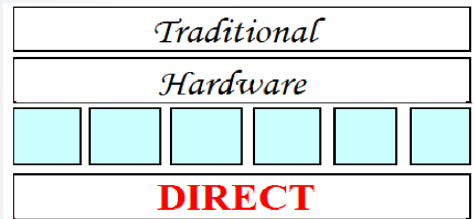

Fasteners for Optimum Performance

THD079 Claw Fastener with Knurled Knob – Non Locking

Finishes Available



THD079

Height 30mm

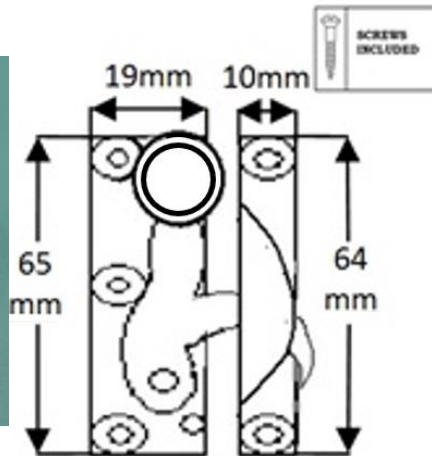

Specification

Material : Brass
 Weight : 119 grams inc screws
 Size of Plate: 65mm x 19mm
 Height of Product : 30mm
 Sold as : Each
 With Screws : 5 Number 19mm x 4
 E.B. Raised Head, Countersunk,
 Slotted, Steel W/S
 Inner Box Quantity : 10
 Outer Box Quantity : 100

| Part No. | Description | Finish |
|------------|---|---------------------|
| THD079/PB | Claw Fastener with Knurled Knob - Non Locking | Polished Brass |
| THD079/CP | Claw Fastener with Knurled Knob - Non Locking | Chrome Plated |
| THD079/SCP | Claw Fastener with Knurled Knob - Non Locking | Satin Chrome Plated |
| THD079/SNP | Claw Fastener with Knurled Knob - Non Locking | Satin Nickel Plated |
| THD079/AB | Claw Fastener with Knurled Knob - Non Locking | Antique Brass |
| THD079/AN | Claw Fastener with Knurled Knob - Non Locking | Antique Nickel |
| THD079/BRO | Claw Fastener with Knurled Knob - Non Locking | Bronze |
| THD079/BLP | Claw Fastener with Knurled Knob - Non Locking | Black Polished |

NOTE : This product is made from Cast Brass and manufactured using the Traditional Sand Cast method. The items requiring a Lacquer protection are protected using the Electrophoretically Lacquered process giving a very attractive long-lasting product. Traditional Hardware Direct will Guarantee the product against product failure due to manufacturing defects under normal usage for a period of 10 years from the date of purchase (for further information see our website). When cleaning the product, use a cloth soaked in warm soapy water and dry off using a clean dry cloth – Do not use any chemical cleaners as this will harm the product and will break down the lacquer and tarnish the product. Due to the nature of the manufacturing process, a tolerance of + / - 5 % must be allowed on the weight and dimensions given on this product

For further information Call Sales on 01254 773945 or visit our website : www.traditionalhardwaredirect.com